

Designing Intercultural Knowledge Communication Environment

A Case Study of YMC-Viet

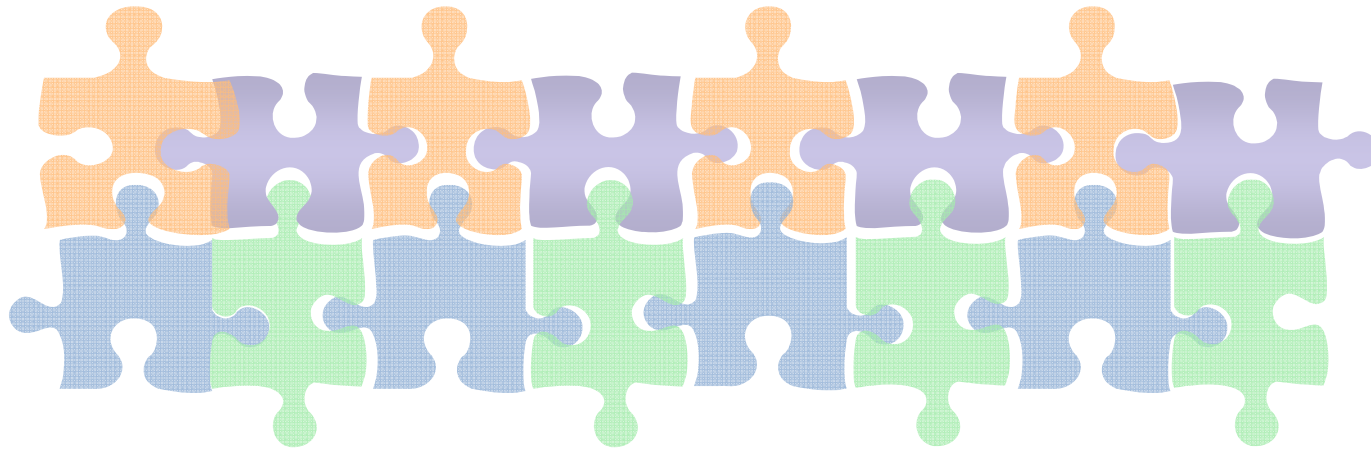

Toru Ishida† Donghui Lin†
Masayuki Otani‡ Reiko Hishiyama‡

† Department of Social Informatics, Kyoto University
‡ Faculty of Science and Engineering, Waseda University

Our Idea is to Realize Agricultural Knowledge Communication between Japanese Experts and Vietnamese Farmers via Youth

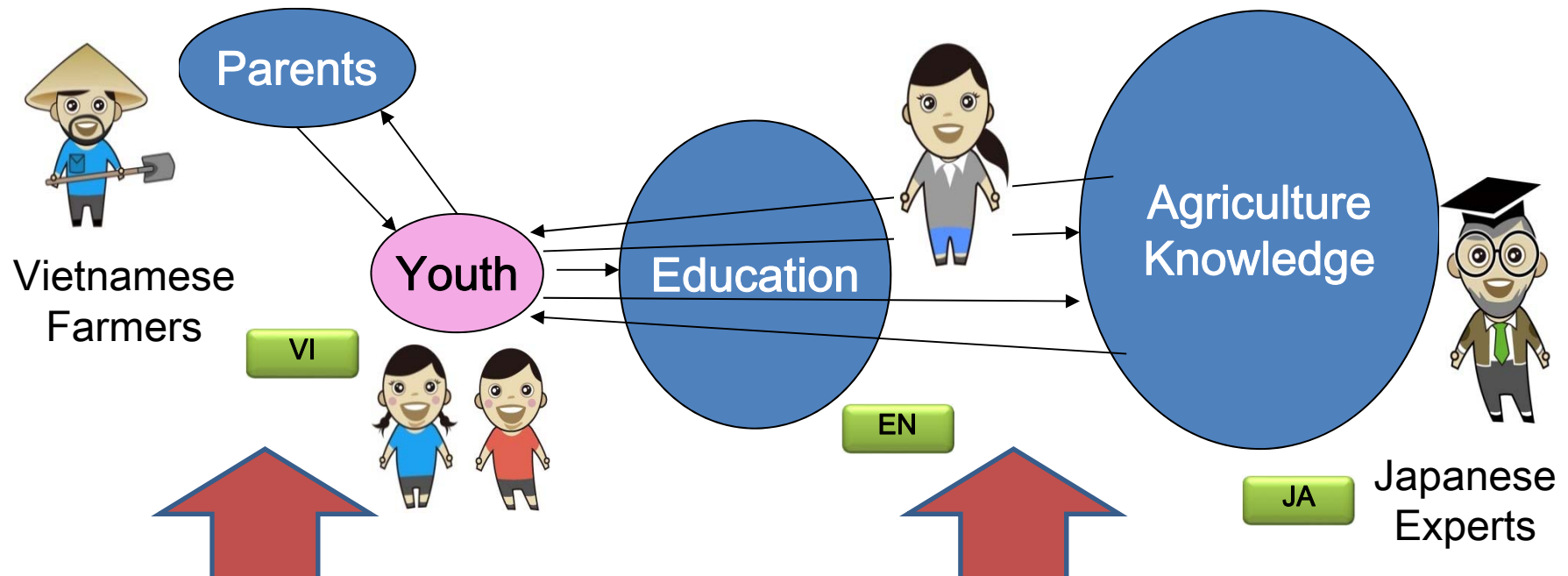

Other Media Includes

- Mobile Phones
- Sensors
- Passports
- Recipe Cards

The Language Grid Provides

- Japanese-English-Vietnamese Translation
- Agricultural Dictionaries
- Agricultural Parallel Texts
- Vietnamese Speech Synthesis

YMC-Viet is a Project Organized by Different Stakeholders

- Organizations

- NPO Pangaea: Planning, Management, Conduct Experiments
- MARD, DARD: Arrangement of Experiments
- University of Tokyo, Mie University : Agricultural Knowledge
- **Kyoto University: Multilingual Knowledge Communication**
- Vietnam National University : Organizing Workshops



- Experiments

- 2011/02 ~ 2011/03 1st Experiment (Thien My, Vinlong Province)
- **2012/10 ~ 2013/01 2nd Experiment (Thien My, Vinlong Province)**
- **2013/09 ~ 2014/01 3rd Experiment (Thien My and Dong Thanh, Vinlong Province)**
- **2014/02 ~ 4th Experiment (Dong Thanh, Vinlong Province)**



Oct. 2012 ~ Jan. 2013, 15 youth participants



Example Experiment Schedule

Each Experiment Takes 5 Months

?

ID:131

これがたんぼにいます。

!

Yaz
場所:
専門分野:
やりたいこと:

こんにちは、Chocon。この卵はスクミリンゴガイです。
どうすれば良いかファシリテーターに聞いてください。

02/12/2012
11:13

Status

Bình
Tuổi: 11
Việc em thích làm:
Người em thích: Cha

Hạt giống lộ ra khỏi mặt đất. Tôi nên làm gì?

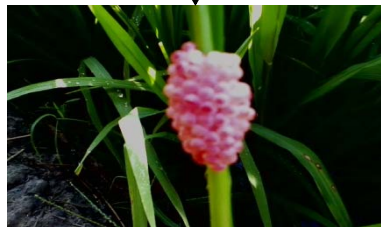
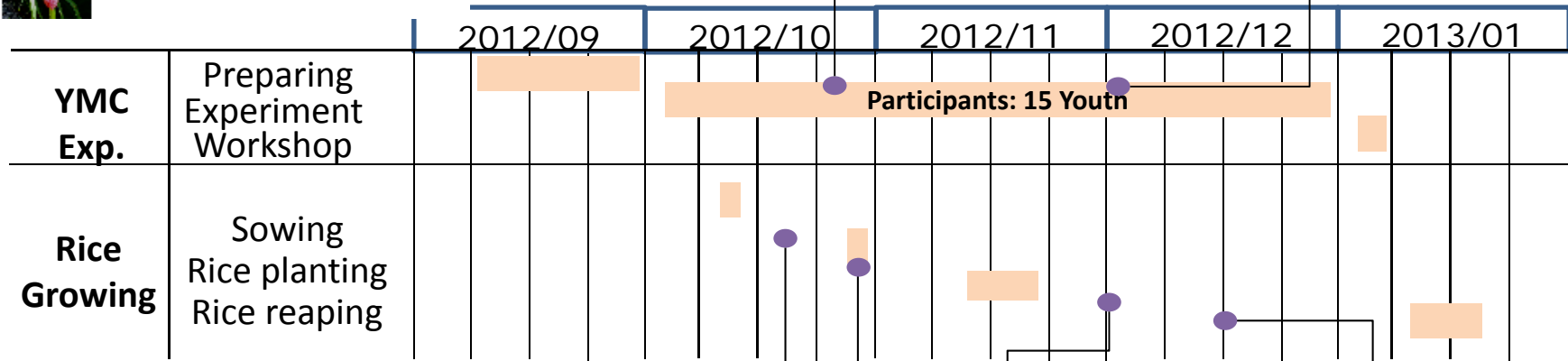

2012/10/19 Chocon



2012/10/29 Phuc



2012/12/1 Bang



2012/12/15 Phuc

Kyoto University provides the Language Grid,
a Service Infrastructure for Multi-Language Communication

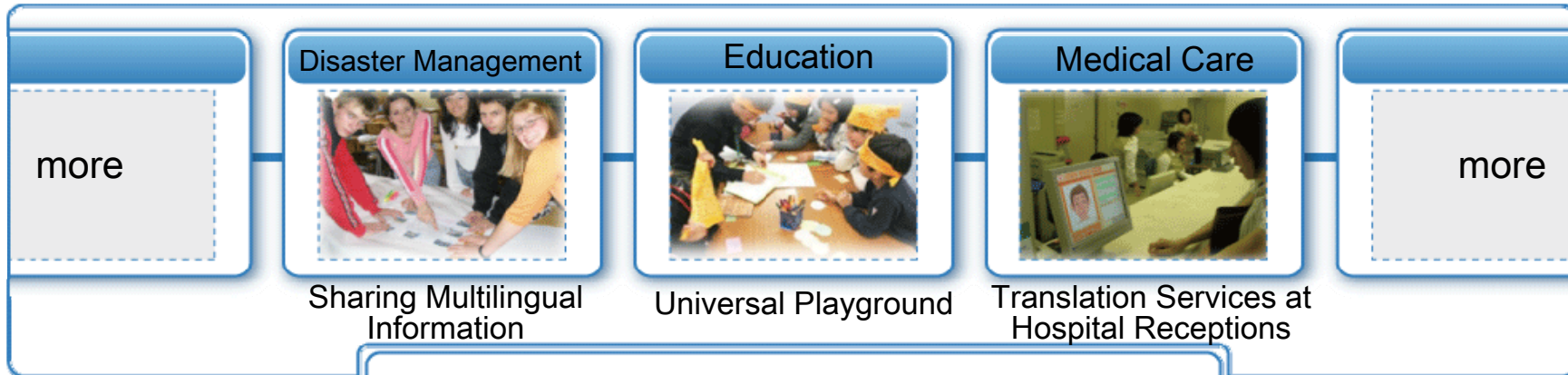

Language Support for Multicultural Societies

177 Language Services are Available

Language Grid



150 Groups from 17 Countries Participates

Sharing Language Resources such as Dictionaries and Machine Translators around the World

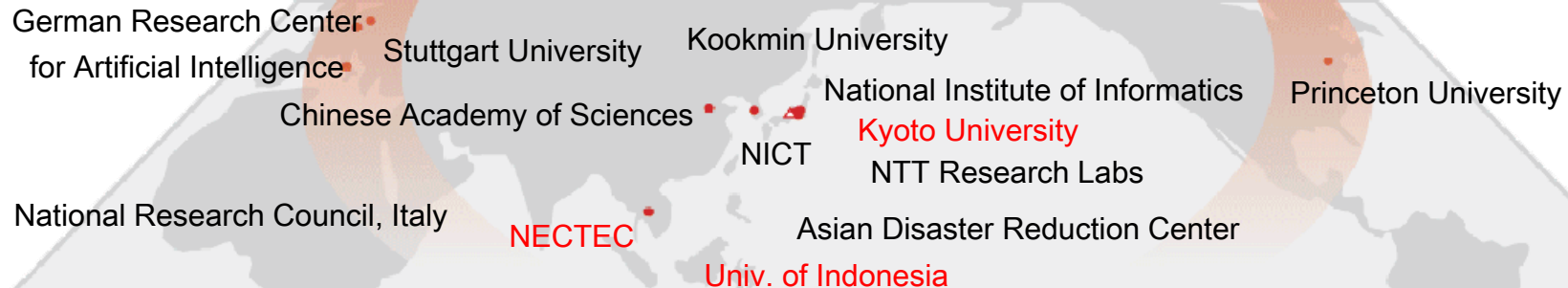

How does the Language Grid Work?



Japanese: たんぼの準備として、田起こしや代掻き、あぜぬりをして下さい。
Vietnamese: Chuẩn bị đất là kết hợp giữa canh tác đất, cày bừa và đắp bờ.
(English: Land preparation is a combination of tillage of the soil, paddling and levee painting.)

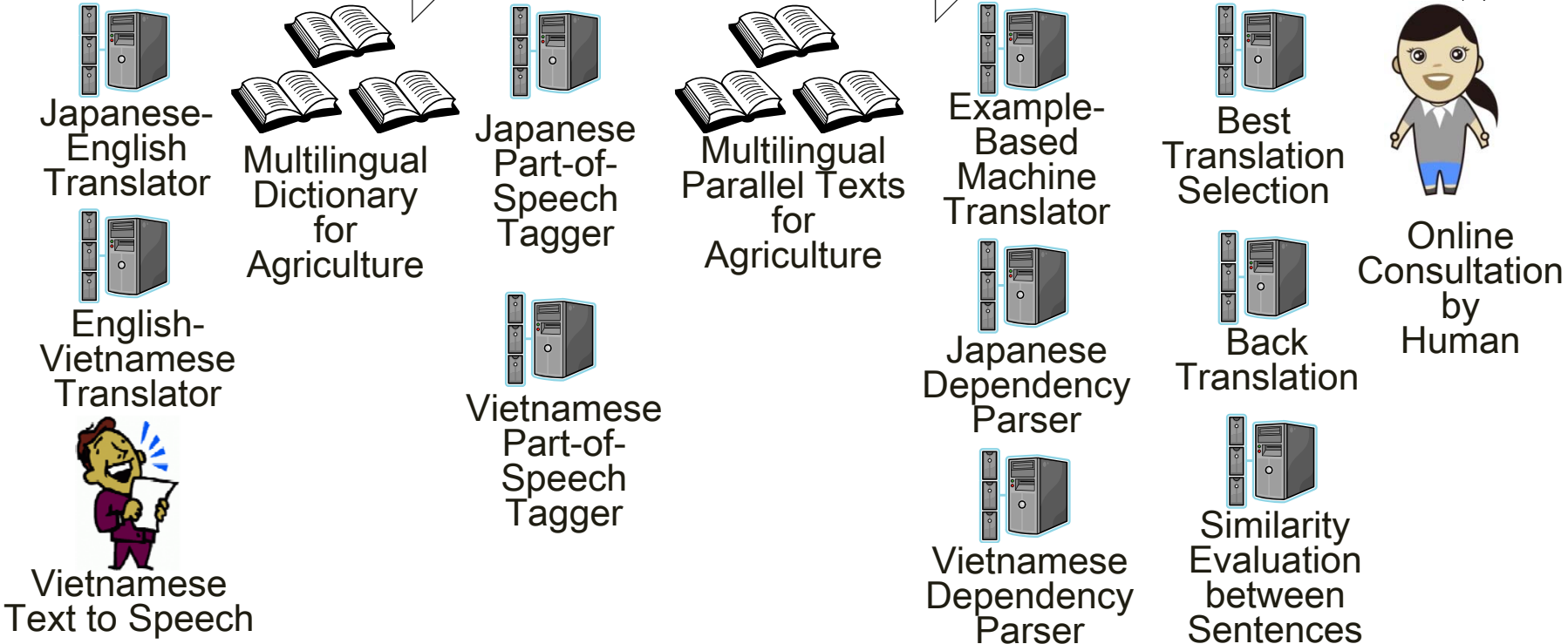
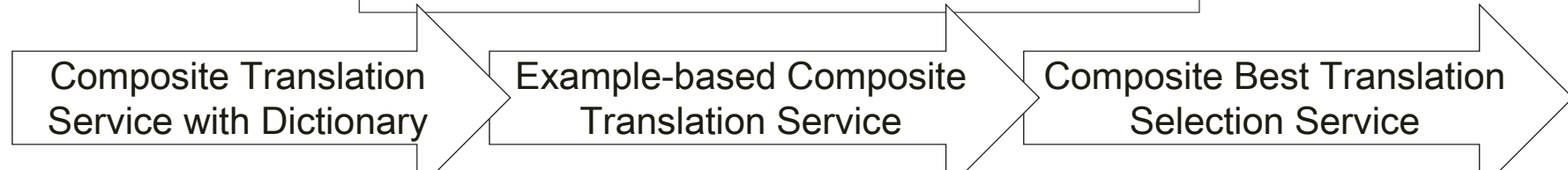

Refinement of Language Communication Channel

Language Communication Model in 1st Season

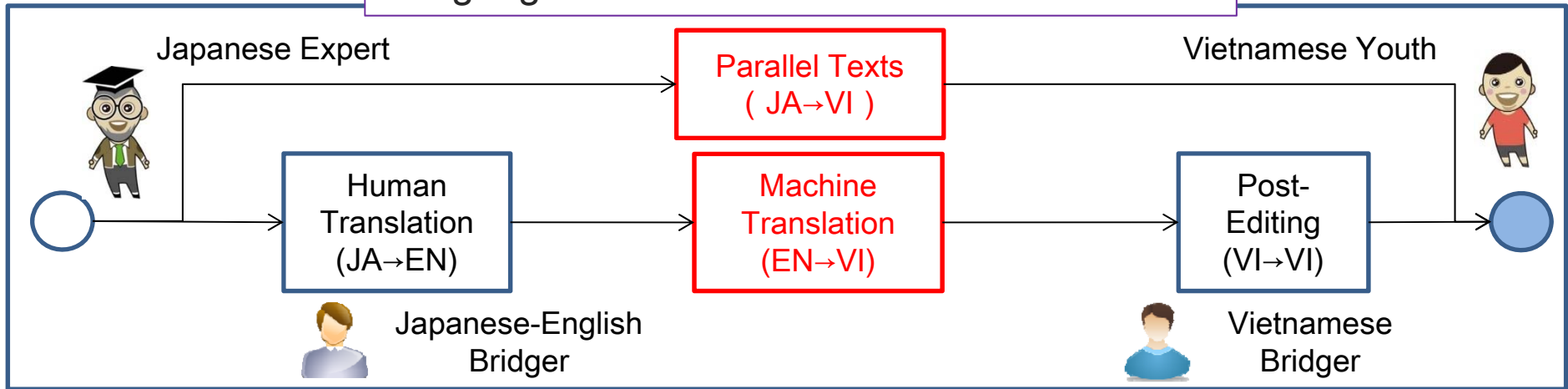

- Enabling monolingual bridger for all languages
- Improving agricultural dictionaries and parallel texts

Language Communication Model in 2nd Season

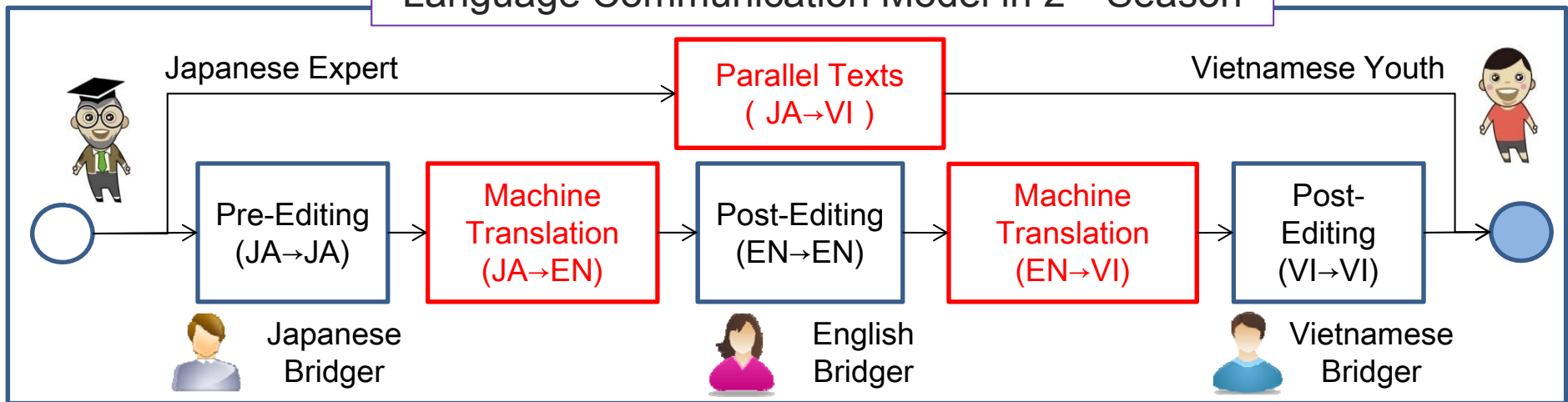

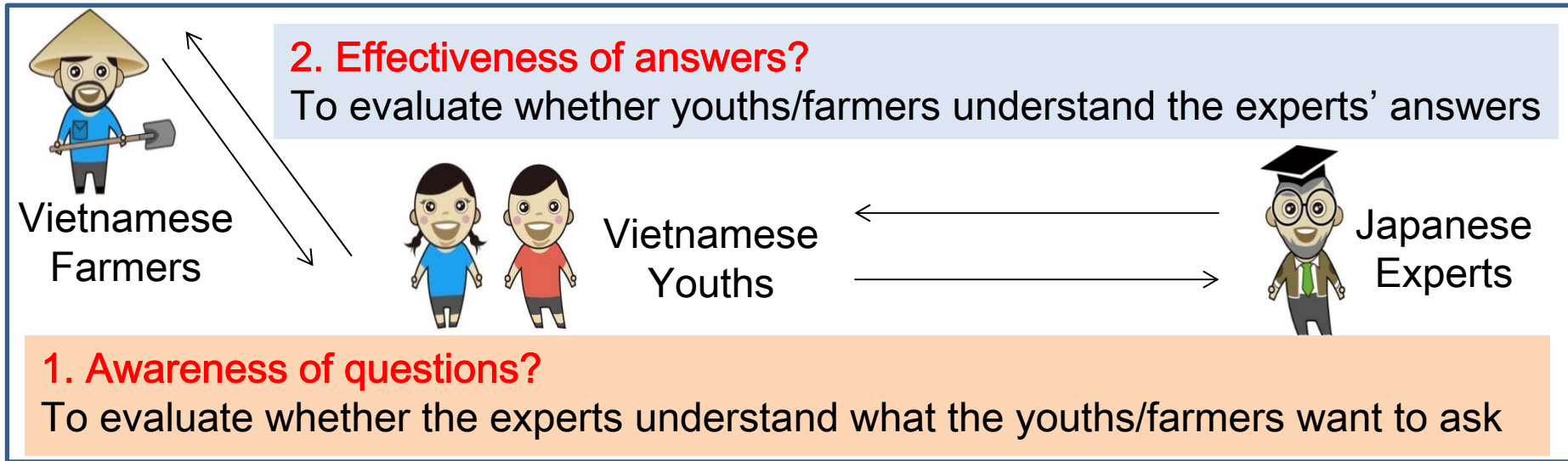

Interview with 4 Japanese experts in Kyoto, Tokyo and Tsukuba, Japan, in 2013/07.
(400+ pages of interview sheet, 8 hours in total.)

Interview with 14 families of Vietnamese youths / farmers in Tra On district, Vietnam, during 2013/08/29-2013/09/07.
(400+ pages of interview sheet, 8 hours in total.)



Awareness of questions

Intention of the Youth:

Problems occurred in the paddy

Understanding of the Expert:

Youth only wants to learn knowledge

(Negative impact on knowledge transfer)

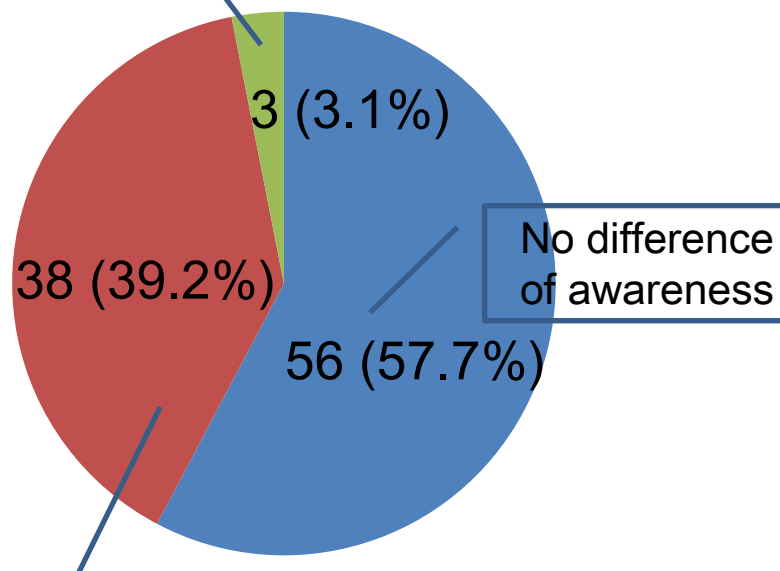

No difference of awareness

Intention of the Youth:

Want to learn some knowledge



Understanding of the Expert:

Problems occurred in the paddy

(No negative impact on knowledge transfer)

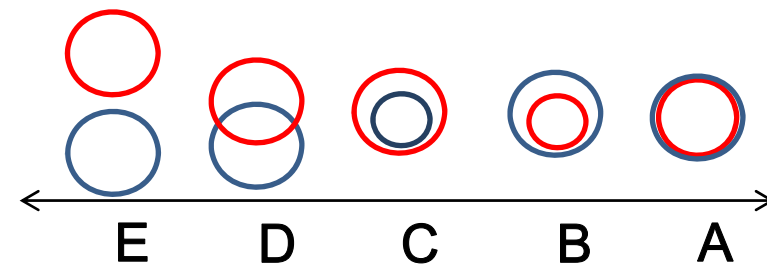
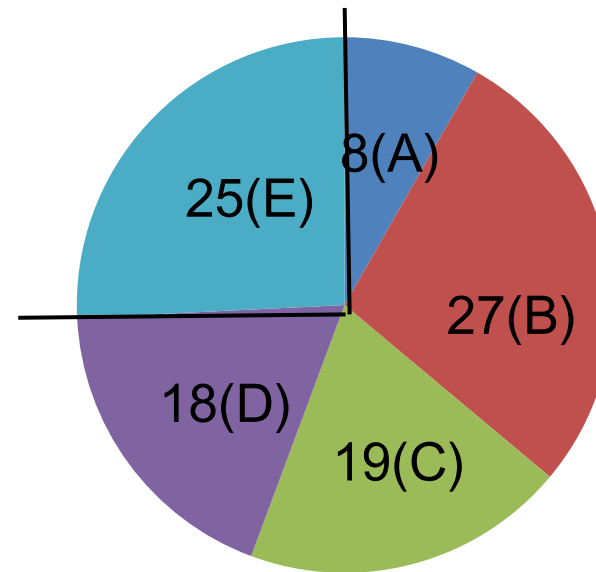
Effectiveness of answers



-  Experts' understanding of important part in the answer
-  Youths' understanding of important part in the answer

Knowledge Communication is a Value Co-Creation Process through Exchanging Agricultural Data and Knowledge

